

Product No. **UP-1109-6-DB**

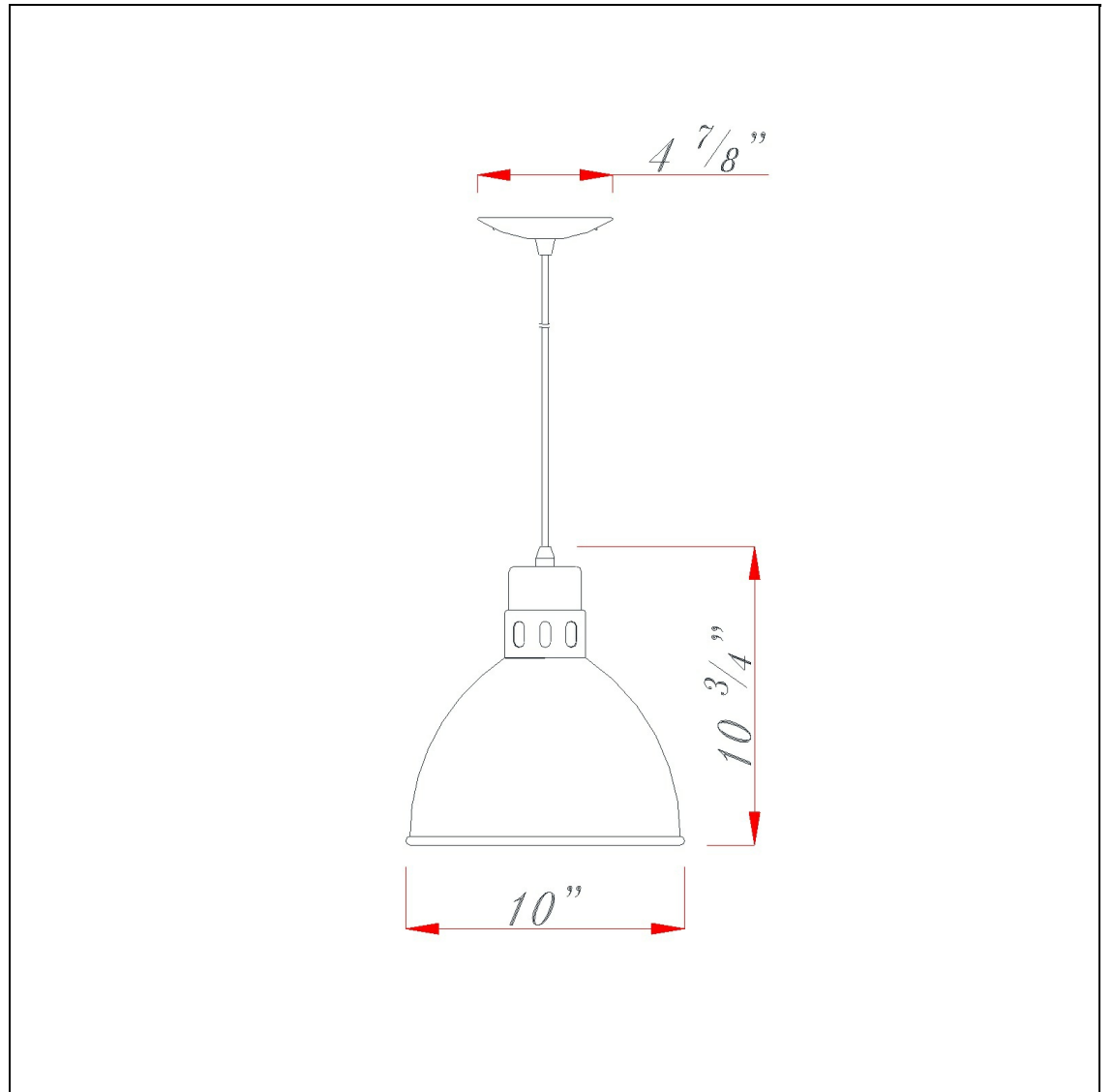

Description

150W Webster Metal Pendant
Durable Metal Construction
Ships in One Carton
Canopy Included
72" Inch Cord Length
72" Inch Cord Length
10.75" Tall Metal Pendant in Brushed Steel

Technical Specifications

UPC	020193067284	Carton 1 Dimensions	13.30 x 22.50 x 22.50
Wattage	150W	Carton 2 Dimensions	0.00 x 0.00 x 22.50
CRI	N/A	Package Dimensions	L: 22.50 W: 22.50 H: 13.30
Lumen	N/A		
Switch Type	Hardwired		
Bulb Base	E26		
Number of Lights	1		
Color	Dark Bronze		
Base Color	Dark Bronze		