

Product No. **FX-3670-9**

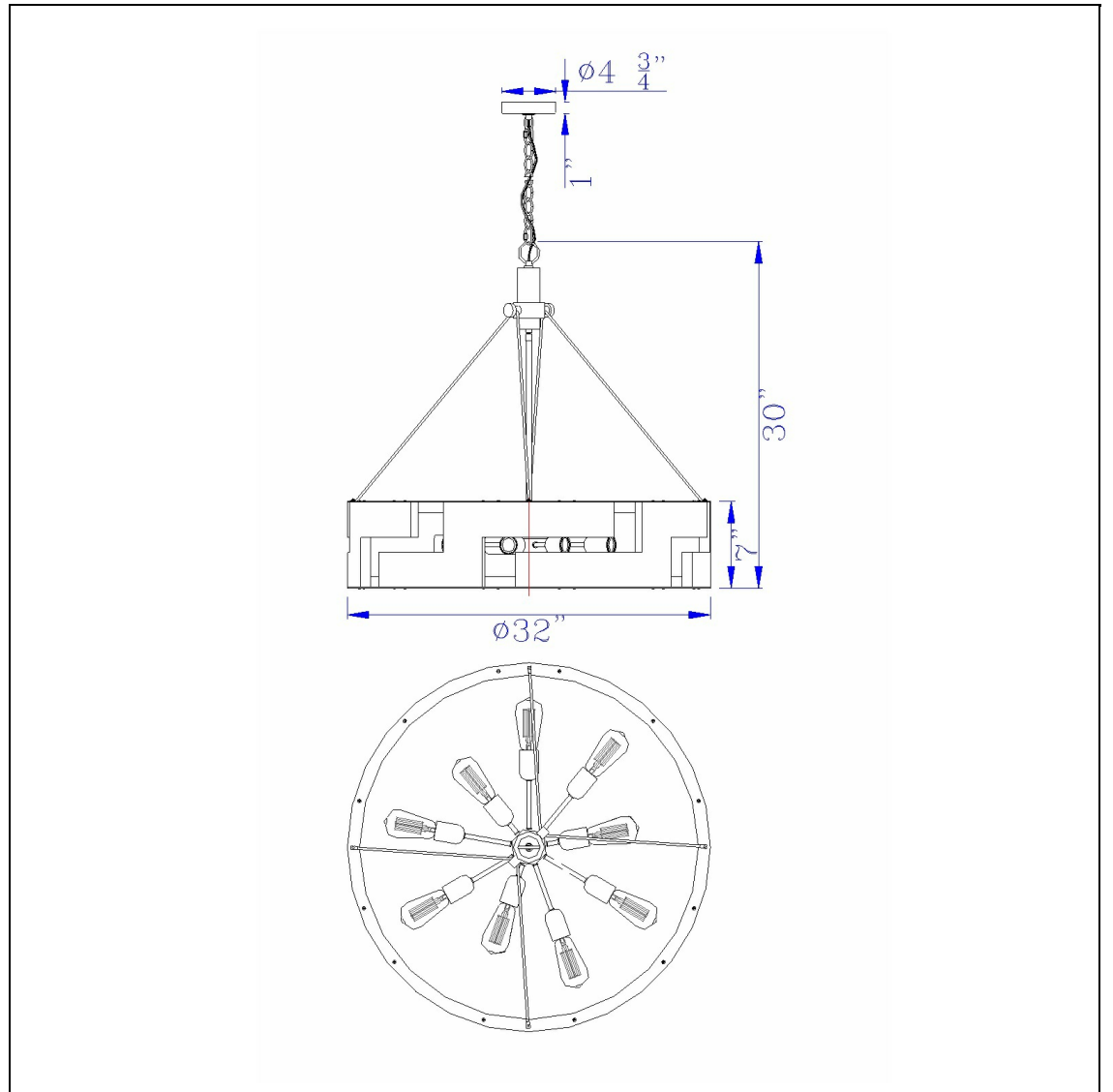

Description

60W X 9 Bradford Metal And Wood Chandelier (Edison Bulbs Not included)
Durable Metal and Wood Construction
Ships in One Carton
Smoky Wood Accents
Smoky Wood Accents
30" Height Metal Chandelier in Smoky Wood Finish

Technical Specifications

UPC	020193067284	Carton 1 Dimensions	11.10 x 34.10 x 34.10
Wattage	60WX9	Carton 2 Dimensions	0.00 x 0.00 x 34.10
CRI	N/A	Package Dimensions	L: 34.10 W: 34.10 H: 11.10
Lumen	N/A		
Switch Type	Hardwired		
Bulb Base	E26		
Number of Lights	9		
Color	Smoky Wood		
Base Color	Smoky Wood		