

Product No. **FX-3721-6**

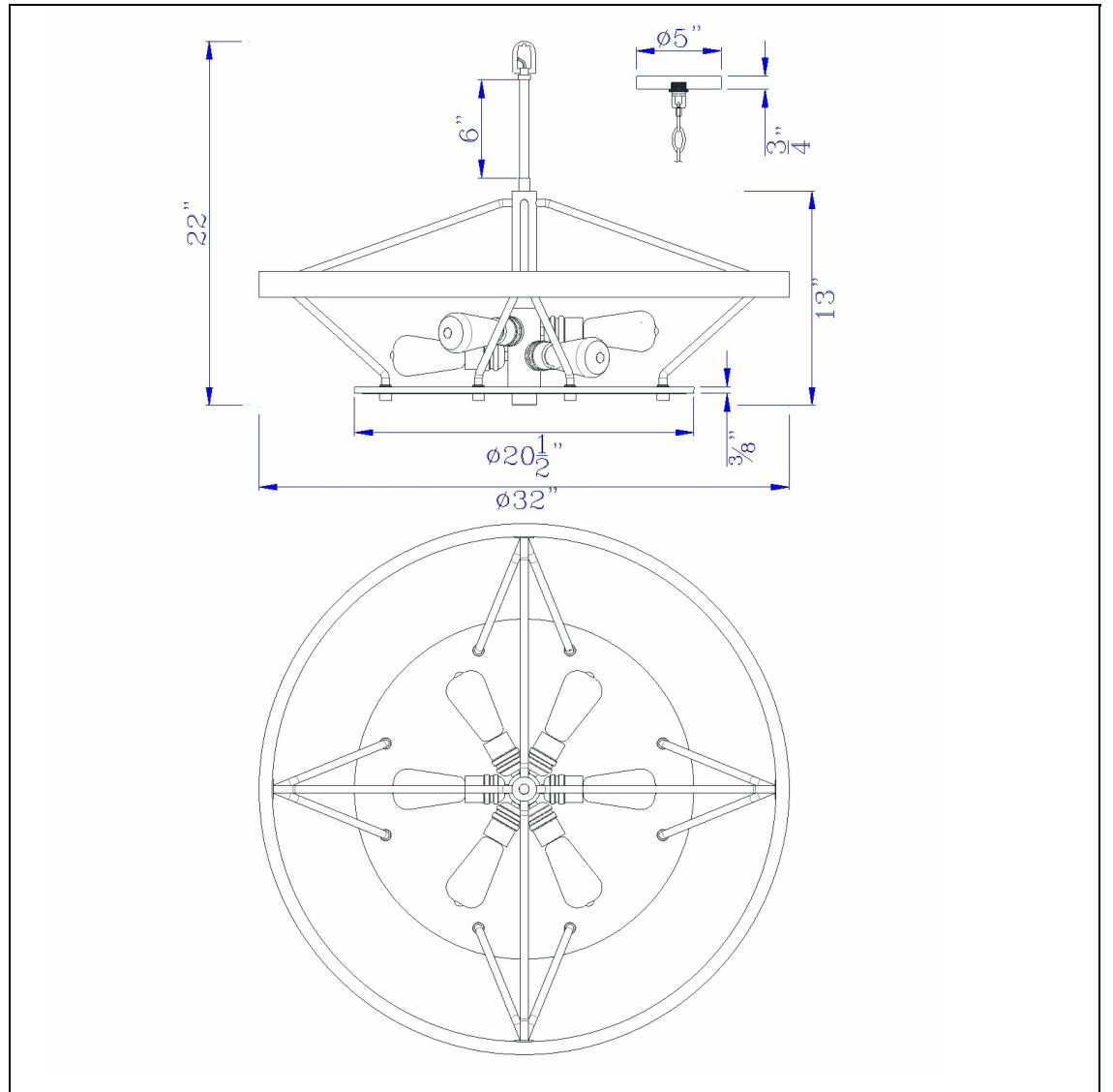

Description

Sherrill Metal/Wood Chandelier (Edison Bulbs Not included)
Durable Metal and Wood Construction
Rippled Glass Diffuser
Round Wooden Accent
5" Diameter Canopy
Ships in One Carton
Ships in One Carton
22" Height Metal and Pinewood Chandelier
in Bronze/Wood Finish

Technical Specifications

UPC	020193067284	Carton 1 Dimensions	17.80 x 34.00 x 34.00
Wattage	60WX6	Carton 2 Dimensions	0.00 x 0.00 x 34.00
CRI	N/A	Package Dimensions	L: 34.00 W: 34.00 H: 17.80
Lumen	N/A		
Switch Type	Hardwired		
Bulb Base	E26		
Number of Lights	6		
Color	Bronze/Wood		
Base Color	Bronze/Wood		