

Product No. **FX-3775-5**

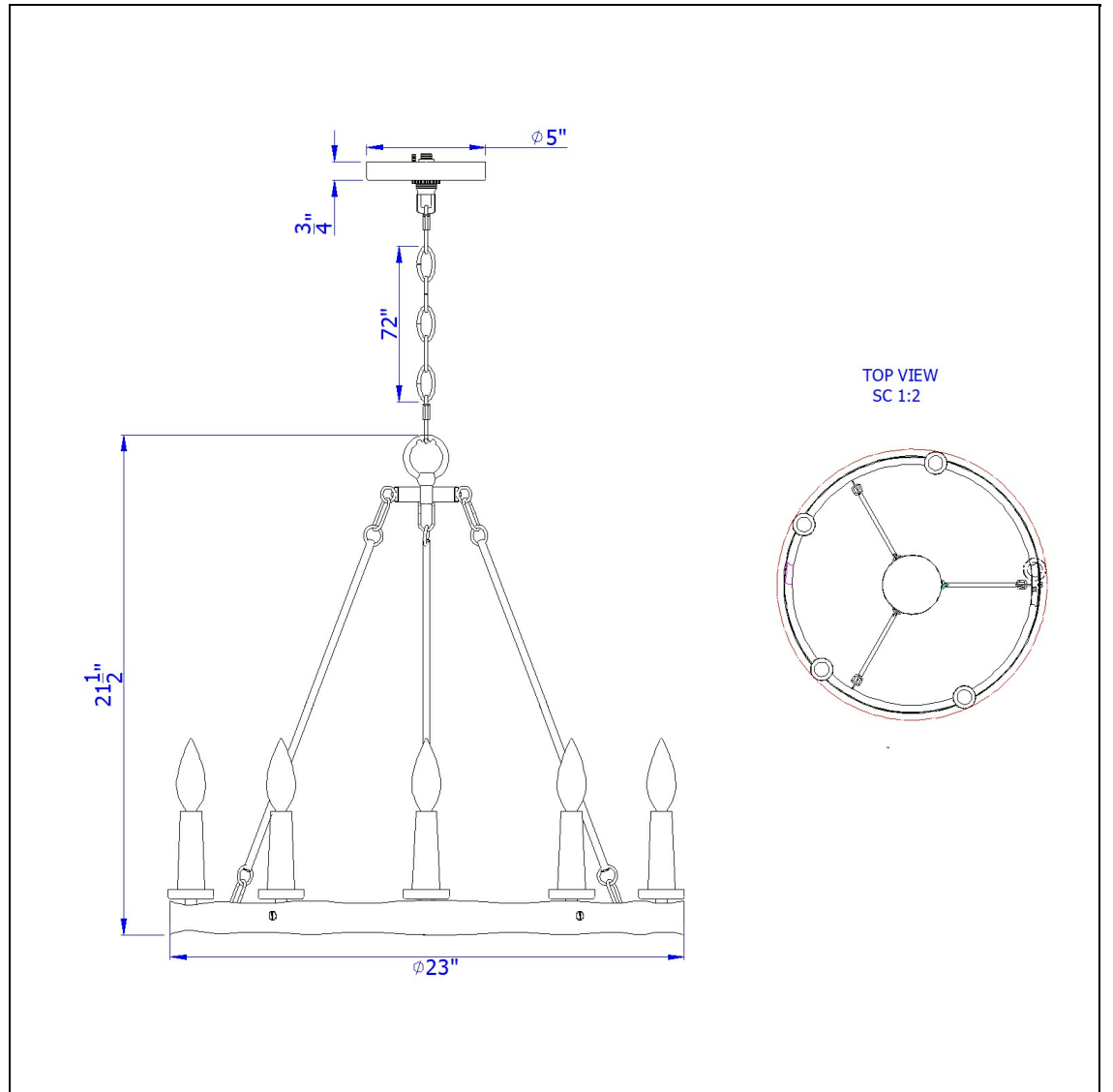

Description

Maidstone metal chandelier with wood finish
Durable Iron Construction
Matte Satin Finish
Circular Wooden Wheel Design
Canopy Included
Includes 6 Feet of Chain
Ships in One Carton
Hardwired
Add a rustic touch to your space with this five light upright chandelier. It features a smooth dark

Technical Specifications

| | | | |
|-------------------------|--------------|----------------------------|---------------------------|
| UPC | 020193067284 | Carton 1 Dimensions | 7.00 x 25.30 x 25.30 |
| Wattage | 60W X 5 | Carton 2 Dimensions | 0.00 x 0.00 x 25.30 |
| Bulb Base | E12 | Package Dimensions | L: 25.30 W: 25.30 H: 7.00 |
| Number of Lights | 5 | | |
| Color | Iron/Oak | | |
| Base Color | Black | | |